

RoHS Compliant

本部品不含有環境管理物質規定之有害物質
kaler part does not contain harmful substances

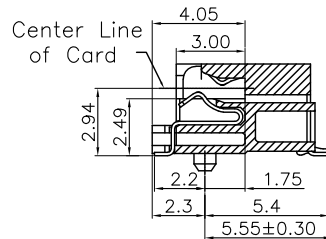
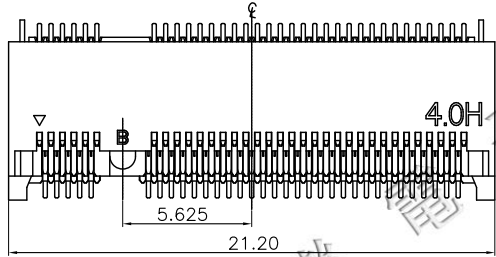

Section: A-A

Notes:

- 1.Kaler Part Material Description
 - 1.1 Housing:High Temperature Thermoplastic, Black UL 94V-0.
 - 1.2 Contact:Copper Alloy,Gold Plating at Mating Area.Matte Tin Plating at Solder Tail, All over Nickel.
 - 1.3 Leg:Copper Alloy,Matte Tin Plating over All, All over Nickel.
3. Ratings
 - 3.1 Voltage Rating: 50V AC (Per pin);
 - 3.2 Current Rating: 0.5A (Per pin);
 - 3.3 Operating Temperature: -25°C ~ 85°C;
4. Electrical Requirement:
 - 4.1 LLCR: 55mΩ Max,(Initial), 20mΩ Max. change allowed(Final);
 - 4.2 Dielectric Withstanding Voltage: 300V AC (RMS) for 1 minute;
 - 4.3 Insulation Resistance: 500MΩ Min. @ 500V DC.
5. Mechanical Requirement:
 - 5.1 Mating Force: 20N Max.
 - 5.2 Unmating Force: 20N Max.
 - 5.3 Durability: 60 Cycles.

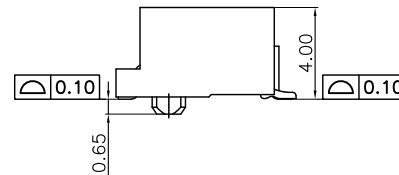
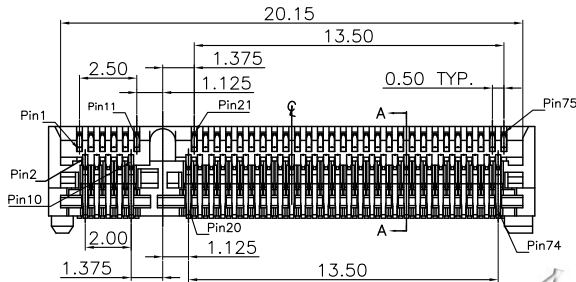

NF09-01B0 x

Contact plated:

- 1:Contact area G/F, Solder tail G/F;
- 2:Contact area Au 3u", Solder tail G/F;
- 3:Contact area Au 5u", Solder tail G/F;
- 4:Contact area Au 10u", Solder tail G/F;
- 5:Contact area Au 15u", Solder tail G/F;
- 6:Contact area Au 30u", Solder tail G/F;

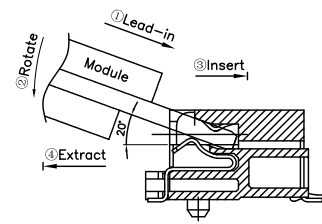
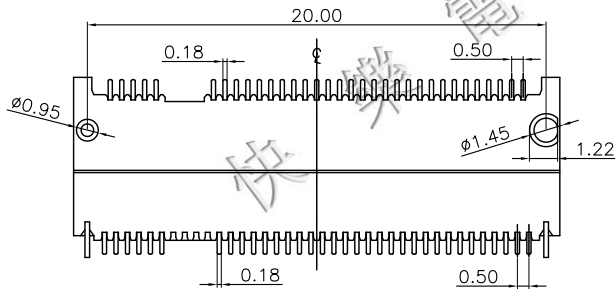

How to mate and unmate
Mate: ①- ②- ③
Unmate: ④

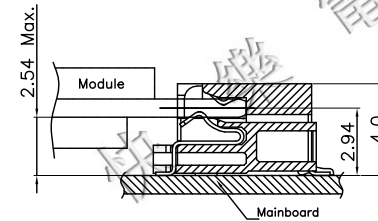

SCALE	N/A	DESIGNER	CHEN	22/09/22
REV	A	CHECKED	PANG	22/09/22
SHEET	1	APPROVE	JOHN	22/09/22

UNLESS OTHKRWISE SPECIFIED DIMENSIONS ARE IN mm

DIMRNSION	TOLERANCE
.XX	± 0.20
.X	± 0.30
X .	± 0.50
ANGULAR	± 3°
UNIT	mm



快樂電子有限公司
KALER ELECTRONICS CO.,LTD.

REVISIONS				
REV.	ECN NO.	LOCATION	DESCRIPTION	DATE
			INITIALRELEASE	

TITLE:	NGFF Socket (M.2 Conn.) 4.0H, STD B Key
PART NO.	NF09-01B01
DWG.NO.	

RoHS Compliant 

本部品不含有環境管理物質規定之有害物質
kaler part does not contain harmful substances

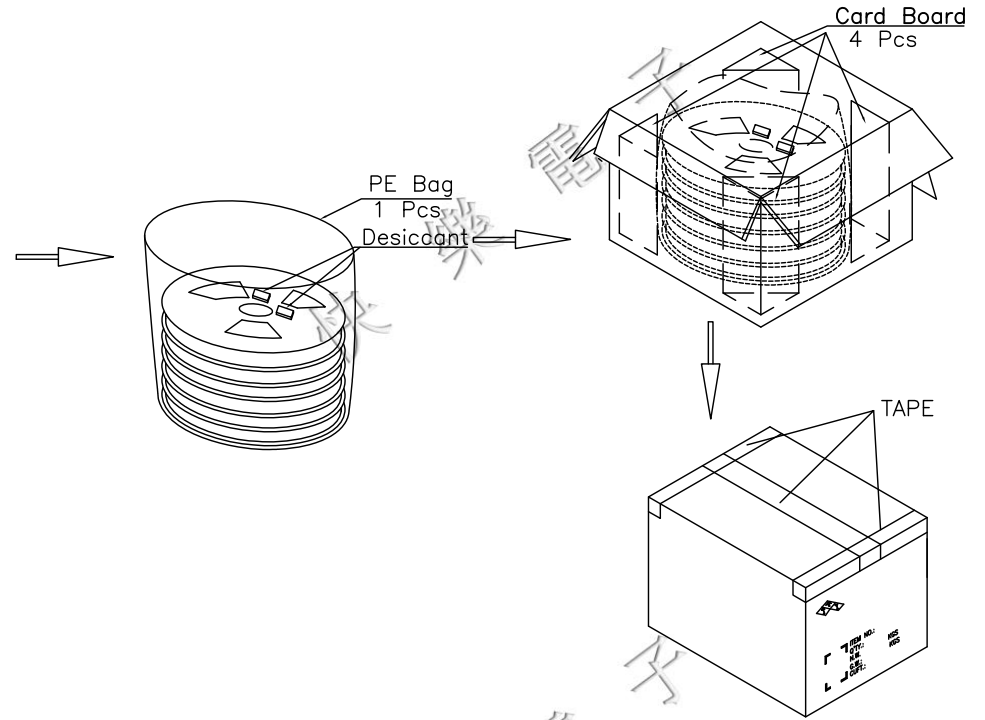
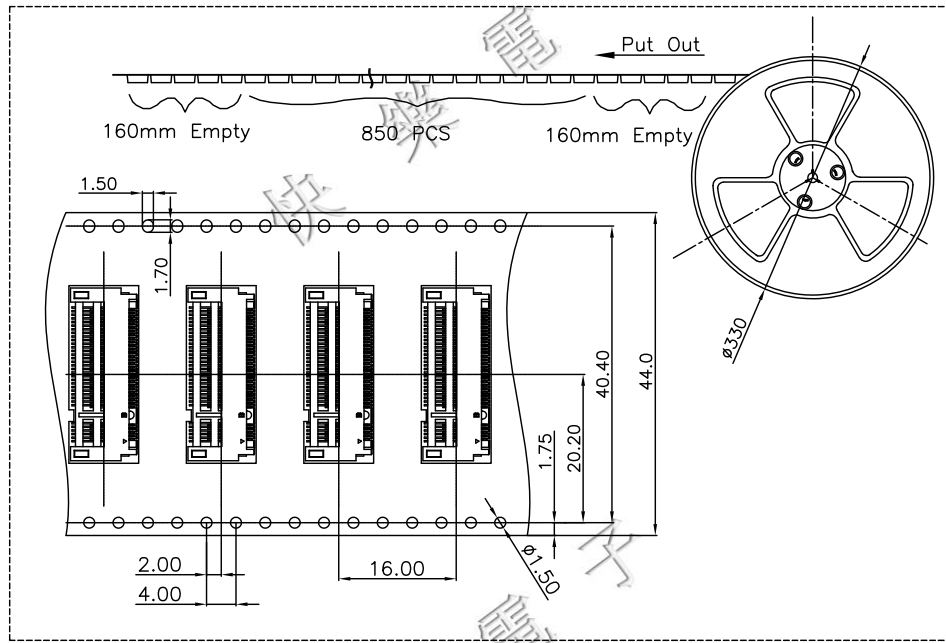

Notes:

1. Peel off force of top tape: 0.1~1.3N;
2. 850 pcs/reel, 5950 pcs/carton.

SCALE	N/A	DESIGNER	CHEN	22/09/22
REV	A	CHECKED	PANG	22/09/22
SHEET	3	APPROVE	JOHN	22/09/22

UNLESS OTHKRWISE SPECIFIED DIMENSIONS ARE IN mm

DIMRNSION	TOLERANCE
.XX	± 0.20
.X	± 0.30
X .	± 0.50
ANGULAR	± 3°
UNIT	mm



快樂電子有限公司
KALER ELECTRONICS CO.,LTD.

REVISIONS				
REV.	ECN NO.	LOCATION	DESCRIPTION	DATE
			INITIALRELEASE	

TITLE:	NGFF Socket (M.2 Conn.) 4.0H, STD B Key
PART NO.	NF09-01B01
DWG.NO.	